

Rotary Valves



Rotary Valves

Putting Dust In Its Place

A high performance Donaldson® Torit® dust collector is only the first step in getting rid of dust efficiently and effectively. Integrate a Donaldson Torit rotary valve with the collector to create a complete system that automatically and continuously transfers dust from the hopper to the conveying system or collection container.

A rotary valve is one middleman it doesn't pay to eliminate. A Donaldson Torit rotary valve reduces downtime and labor by taking dust disposal out of employees' hands. And all Donaldson Torit rotary valves are designed with a precise seal that keeps air out of the hopper and safeguards the performance of the collector.

Whether disposing of dust, using it in other processes or selling it to other manufacturers, a Donaldson Torit rotary valve is the most economical, productive and efficient way to put dust in its place.

Donaldson Torit rotary valves offer:

- **Fast, efficient automated dust collection and disposal**
- **Continuous dust disposal that keeps hopper and collector operating at peak performance**
- **Reduced dust collector maintenance time and cost**
- **Trustworthy, high quality technology from the leader in industrial air filtration**
- **One-year warranty**

*Automated
Dust
Disposal
from Start
to Finish*



AN Flex Tip
Rotary Valve

Rotary Valves

Automated, Innovative Dust Disposal

Rely on a Donaldson Torit rotary valve to handle the dirty work of dust disposal with ease.

- **Comprehensive** A full line of rotary valves are available in models and sizes to fit most any application from nuisance dust to more challenging sticky and abrasive particles.
- **Efficient** A Donaldson Torit rotary valve allows complete automation of a dust collection system from start to finish, continuously depositing dust from the collector to the end-of-the-line material handling system.
- **Innovative** A precise seal eliminates dust build-up in the hopper and prevents air from entering the hopper discharge, which can seriously compromise filter life and impede the collector performance.
- **High Performance** Rotor blade and stationary housings are designed to very high tolerances for reliable, high quality performance and air seal integrity.
- **Cost Effective** A proprietary straight line throat design allows a smaller Donaldson Torit valve to do the job of other manufacturers' larger valves, which can reduce the cost of dust disposal.



CI Cast Iron
Rotary Valve



F - Series Feeder
Rotary Valve

Rotary Valves

Sizes & Operations

Normal Operations For AN Rotary Valves

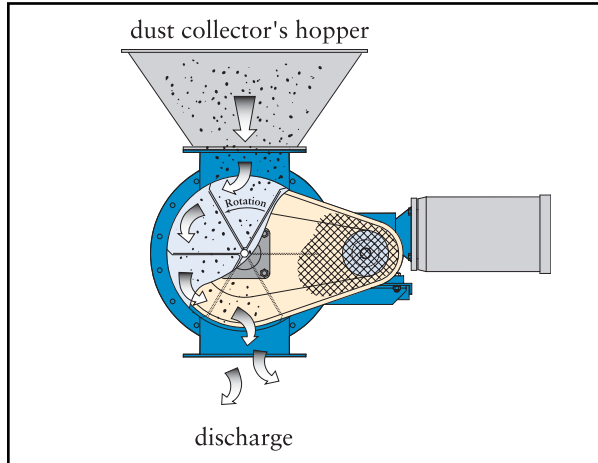

AN Rotary Valves

- Economical solution for automated handling of most discharge dust.
- Rugged one-piece design features a double wiper rotor for a precise seal in low air pressure applications.
- Extended length wipers allow larger chunks to pass on models 8-16 AN.
- Eight sizes: 6", 8", 10", 12", 16", 20", 24" and 30".

Normal Operations For CI Rotary Valves

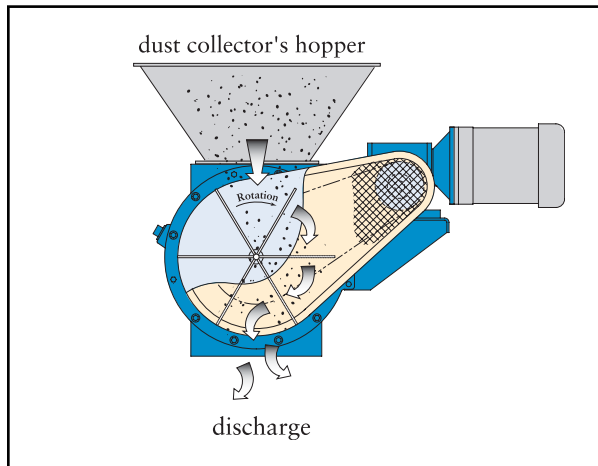

CI Rotary Valves

- Designed to handle wood, grain and solid chemicals. Adaptable for use with difficult dust including sugar, clay and calcium carbonate.
- Well-suited for high pressure pneumatic conveying systems.
- Machined and flexible tip rotor models available.
- Handles 3-4 times more material than other valves with the same inlet opening.
- Change bearings without disassembling the entire valve.
- Six sizes: 6", 8", 10", 12", 15" and 21".

Normal Operations For F - Series Rotary Valves

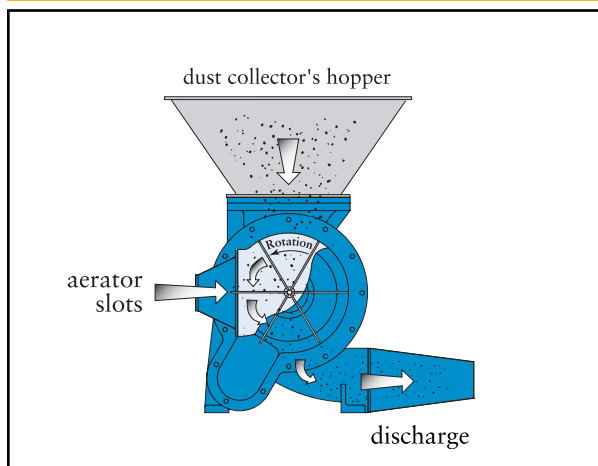

F - Series Rotary Valves

- Designed for use with dry granular materials and can be adapted for difficult sticky dusts.
- Features exclusive Air Swept design that uses air from a blower to aerate material moving through the valve to eliminate pocket buildup.
- Can serve as a pneumatic conveying system when used with a positive displacement blower.
- Heavy-duty machined feeder valve construction of a cast body and endplates, with a welded machined 12 plain blade rotor.
- Five sizes: FS-A, FS-B, FS-C, FS-D and F-E.

Rotary Valves

Dimensions & Specifications

AN ROTARY VALVES

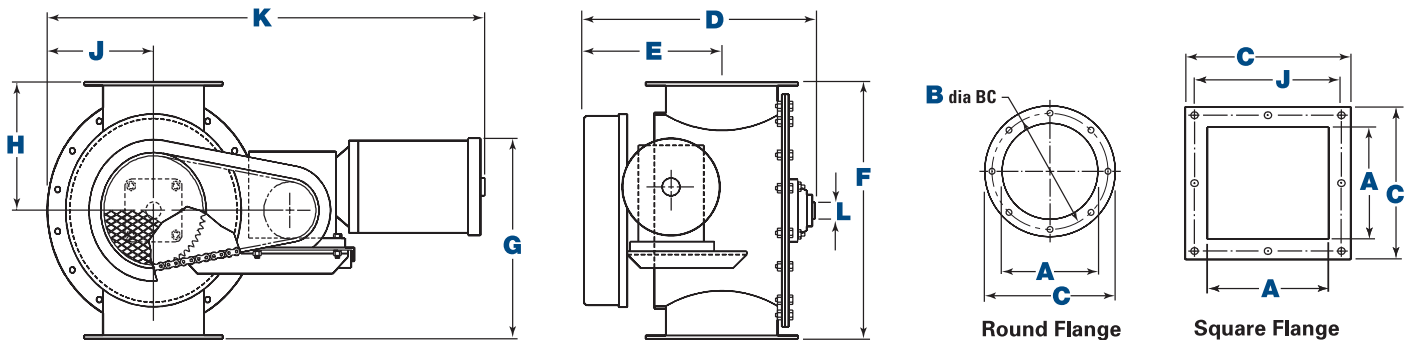

Size	No. of Holes		Valve Capacity* (rpm)	Valve Capacity* (cu ft/rev)	Drive Motor hp (10-blade mach.)	Approx. Shipping Weight** (lbs)	Dimensions (inches)										
	(rnd)	(sq)					A	B	C	D	E	F	G	H	J	K	L (Valve Shaft)
6	8	8	22	0.2	1/3 or 1/2	145	6.3	8.0	9.3	14.3	8.8	15.0	12.1	7.5	6.9	32.6	1.2
8	8	12	22	0.6	1/2 or 3/4	195	8.3	10.0	11.3	17.1	10.2	19.0	14.1	9.5	8.6	36.7	1.3
10	12	16	22	1.3	1/2, 3/4 or 1	290	10.3	12.0	13.3	19.0	11.2	23.0	16.5	11.5	10.6	40.9	1.4
12	12	16	22	2.5	3/4, 1 or 1.5	380	12.3	14.0	15.3	21.2	12.3	27.0	19.9	13.5	12.6	47.3	1.4
16	16	20	22	6.2	1, 1.5 or 2	600	16.3	18.0	19.3	25.6	14.6	35.0	23.9	17.5	16.6	55.5	1.7
20	24	24	20	12.6	1.5 or 2	935	20.4	22.0	23.4	31.0	17.5	43.4	28.1	21.7	20.7	63.6	2.2
24	24	28	18	21.0	1.5 or 2	1300	24.5	26.1	27.5	35.0	19.4	49.5	31.1	24.8	23.8	69.9	2.2
30	32	32	15	43.0	3 or 5	2000	30.5	32.1	33.5	41.0	22.4	61.5	37.3	30.8	29.8	91.9	2.2

* Volumetric displacement is 100% as listed. Capacity selection is from 40% to 60%. Maximum recommended speed is 30 rpm.

** Shipping weight includes complete valve with gear motor drives.

Rotary Valves

Dimensions & Specifications

CI ROTARY VALVES

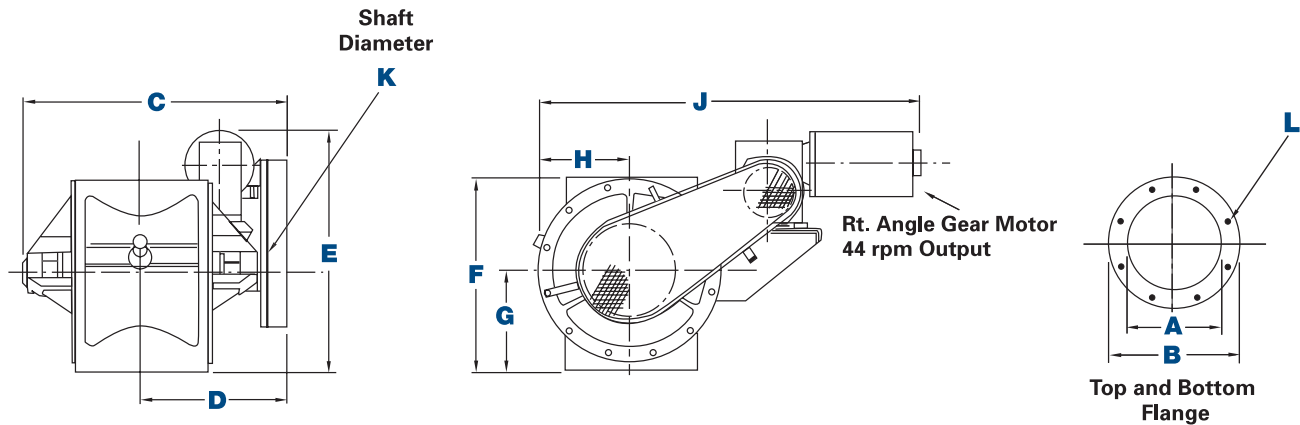

Size	No. of Holes	Valve Capacity* (cu ft/rev)	Drive Motor hp (10-blade mach.)	Approx. Shipping Weight** (lbs)	Dimensions (inches)										
					A	B	C	D	E	F	G	H	J	K	L
6	8	0.3	1/2	325	6.0	9.3	22.1	12.9	17.7	12.0	6.3	6.3	31.3	1.2	0.4
8	8	0.8	1/2	375	8.0	11.3	24.3	14.1	20.0	16.5	8.5	8.1	35.1	1.2	0.4
10	12	1.6	3/4	525	10.0	13.3	26.9	15.2	25.0	20.8	10.8	10.1	43.4	1.9	0.4
12	12	2.4	1	960	12.0	15.3	28.6	16.0	28.5	25.0	13.0	12.0	47.3	1.9	0.4
15	16	4.6	2	1435	15.0	23.5	34.6	19.7	33.6	33.5	17.0	14.2	52.2	2.4	1.1
21	20	13.4	5	5400	21.0	32.0	58.4	31.5	41.9	45.0	22.5	19.9	76.8	3.3	1.4

* Volumetric displacement is 100% as listed. Capacity selection is from 40% to 60%. Maximum recommended speed is 30 rpm.

** Shipping weight includes complete valve with gear motor drives.

Rotary Valves

Dimensions & Specifications

F - SERIES ROTARY VALVES

*Models: FS-A, FS-B, FS-C, FS-D

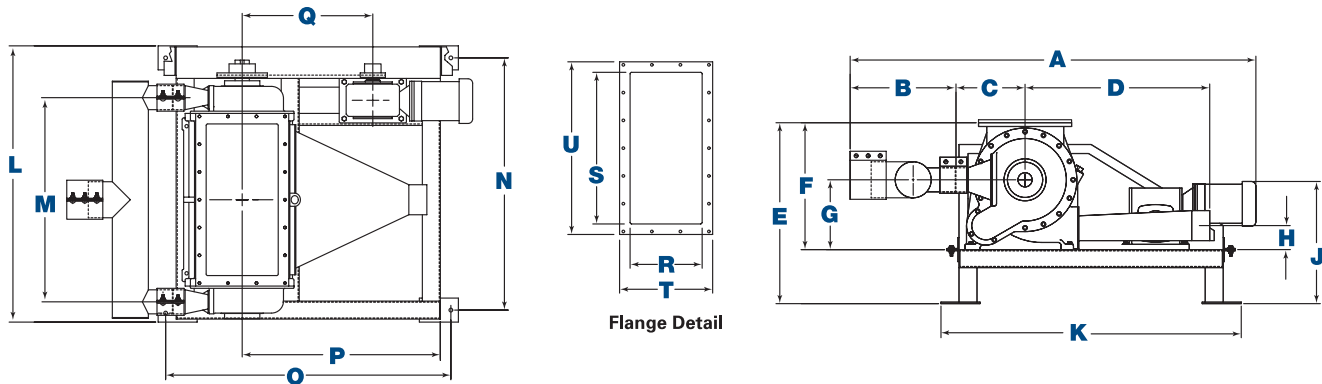

Size	Valve Capacity** (cu ft/rev)	Drive Motor hp (10-blade mach.)	Approx. Shipping Weight*** (lbs)	Dimensions (inches)						
				A	B	C	D	E	F	G
FS-A	0.3	3/4	420	56.4	15.1	9.6	14.6	25.5	17.5	10.0
FS-B	0.6	3/4	575	61.7	15.9	9.6	17.8	25.5	17.5	10.0
FS-C	1.3	1	850	67.5	17.5	11.5	20.1	30.1	21.1	11.6
FS-D	2.3	1	1300	67.6	17.5	11.5	30.8	30.1	21.1	11.6

Size	Dimensions (inches)												
	H	J	K	L	M	N	O	P	Q	R	S	T	U
FS-A	2.6	17.9	36.0	24.0	12.3	21.0	33.5	22.6	15.8	6.8	6.8	10.3	11.3
FS-B	3.1	17.9	41.5	31.0	19.1	28.0	39.0	28.1	20.3	6.8	13.5	10.3	18.0
FS-C	3.6	18.9	50.0	35.0	22.5	31.0	47.5	33.0	22.5	12.0	13.8	15.5	17.3
FS-D	4.0	20.3	50.0	46.0	34.0	42.0	47.5	33.0	21.8	12.0	25.3	15.5	28.8

* Floor base shown, housing drive bracket also available.

** Volumetric displacement is 100% as listed. Capacity selection is from 40% to 60%. Maximum recommended speed is 30 rpm.

*** Shipping weights include drive and floor base.

Rotary Valves

Dimensions & Specifications

*Model: F-E

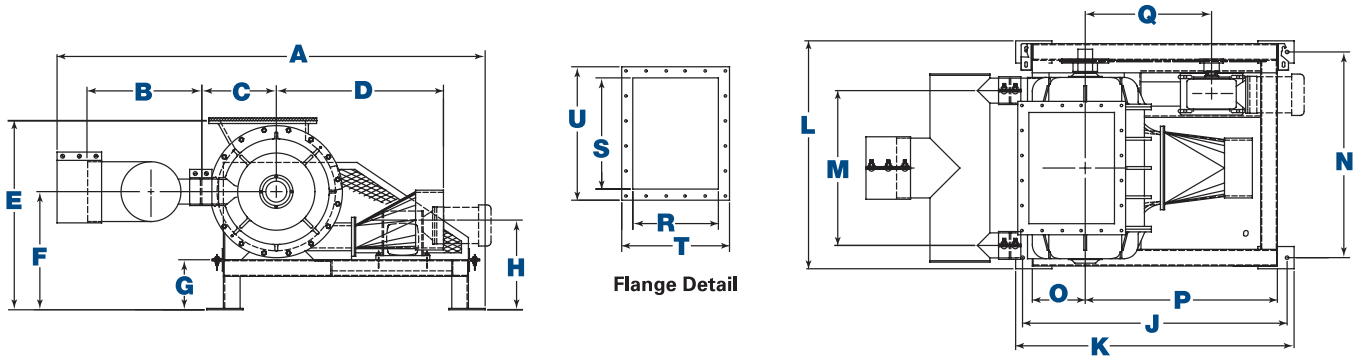

Size	Valve Capacity** (cu ft/rev)	Drive Motor hp (10-blade mach.)	Approx. Shipping Weight*** (lbs)	Dimensions (inches)						
				A	B	C	D	E	F	G
F-E	3.5	3	1600	76.9	20.5	13.4	30.0	34.0	21.3	9.0

Size	Dimensions (inches)												
	H	J	K	L	M	N	O	P	Q	R	S	T	U
F-E	16.1	50.0	47.5	41.0	27.9	37.0	9.5	34.5	22.7	15.4	20.0	19.4	24.0

* Floor base shown, housing drive bracket also available.

** Volumetric displacement is 100% as listed. Capacity selection is from 40% to 60%. Maximum recommended speed is 30 rpm.

*** Shipping weights include drive and floor base.

Rotary Valves

Standard Features & Options

Standard for AN

- 6-blade, double wiper rotor, black neoprene flexible wipers
- Available with round or square flanged inlets and outlets, ranging from 6"-30"
- Maximum operating pressure of 17" wg
- Drive combination includes motor, gear reducer, sprockets, chain and OSHA guard for standard equipment speeds of 17-22 rpm

Options for AN

- EPDM and polyurethane materials available for flex tip rotors to handle material characteristics and process conditions such as temperature, humidity, food grade, etc.
- Extended clearance wipers available for models 8-16
- Extended shaft option allows valve and conveyor to be driven from a common drive
- 5-16 rpm rotation speed can be custom-designed

Standard for CI Flexible Tip Model

- 6-blade fabricated rotor, cast iron body and endplates, with black neoprene flexible blades
- Round inlets and outlets, ranging in size from 6" to 12" ID
- Handles differential pressures up to 1 PSI (6.89 kPa)
- Drive combination includes motor, gear reducer, sprockets, chain and OSHA guard for standard equipment speeds of 17-22 rpm

Options for CI Flexible Tip Model

- EPDM and polyurethane materials available for flex tip rotors to handle material characteristics and process conditions such as temperature, humidity, food grade, etc.
- 5-16 rpm rotation speed can be custom-designed

Machined Model

- 10-blade, machined mild steel rotor with cast iron housing, bearing and endplate
- Seal area has 1/8" pipe tap connection with plug for pressure purge connection; housing has air bleed connection
- Handles differential pressures up to 12 PSI (82.74 kPa)
- Round inlets and outlets, ranging in size from 6" to 12" ID
- Drive combination includes motor, gear reducer, sprockets, chain and OSHA guard for standard equipment speeds of 17-22 rpm

Machined Model

- Available in 8- and 12-blade rotor models
- Available in 15" and 21" inlet and outlet sizes
- Nickel-plated rotor, body and endplates
- Blade options include stellite tipped, cutter blade, beveled blade, machined adjustable tips with 1/4" rubber wipers and Teflon®* coated pockets
- Special design available for sugar applications
- 5-16 rpm rotation speed can be custom-designed

Standard for F - Series

- 12-blade, mild steel rotor with cast iron housing with air bleed connection, two air intake fittings and product discharge connection
- Handles differential pressures up to 20 PSI
- Drive combination includes motor, gear reducer, sprockets, chain and OSHA guard for standard equipment speeds of 17-22 rpm

Options for F - Series

- Nickel-plated rotor, body and endplates
- Alternative blades available, including cutter, beveled, brass tipped, stellite tipped and Teflon®* coated pockets
- Special design available for sugar applications
- 5-16 rpm rotation speed can be custom-designed

* Teflon is a registered trademark of E.I. DuPont de Nemours & Co., Inc.

Donaldson® Torit® Look to Donaldson Torit for all of your air filtration needs. Although you may not always see our products, you can breathe easier knowing we're there.

Customer Support For nearly 90 years, Donaldson Torit has been the leading innovator of air filtration solutions that make manufacturing plants a cleaner environment for employees the world over. Driven by an unwavering commitment to customer support, Donaldson Torit is the name more manufacturers around the globe trust to deliver the most efficient and productive dust, mist and fume collectors and filter media.

Unparalleled Innovation Whether our customers need a single collector or a multi-faceted collection system, Donaldson Torit has the solution. The expanse of Donaldson Torit's innovative product line is unmatched, offering unparalleled filtration systems, ancillary parts and replacement filters. From central, source and ambient systems to baghouse, envelope and cartridge technologies, Donaldson Torit has the expertise to provide filtration solutions for virtually any application.

Global Reach Donaldson Torit manufactures and markets its filtration products throughout the world. As more manufacturers continue to expand and grow their operations globally, Donaldson Torit will be there to serve and support our customers' needs.

Built for Performance Genuine Donaldson Torit replacement filters and parts can significantly improve the performance of your collectors. With hundreds of varieties to choose from and all in-stock orders shipped within 48 hours, Donaldson Torit is your best, most reliable source for premium performance replacement parts. Visit us at www.donaldsondynamic.com.

Rely on the Industry Leader When it comes to air filtration, you need a partner you can trust. Rely on the world leader in air filtration—Donaldson Torit.



Donaldson

Filtration Solutions

Donaldson Company, Inc.
Industrial Air Filtration
P.O. Box 1299
Minneapolis, MN
55440-1299 U.S.A.

Tel 800.365.1331 (USA)
Tel 800.343.3639 (within Mexico)
dustmktg@mail.donaldson.com
www.donaldsontorit.com



Printed in USA

© Donaldson Company, 2002 Rotary Valves 09-2005